

Smart Sensor

SensComp's totally integrated Series 600 Smart Sensor simplifies product design and packaging.

Features

- 50 KHz Electrostatic Ultrasonic sensor
- Integrated SMT Drive Electronics
- TTL Compatible
- Convenient Pin Terminal Connection
- Monostable and Astable Modes of Operation
- Voltage Regulated
- Beam Angle of 15° at -6 dB
- Low Ring Characteristics
- Ranges from 6" to 35'
- Excellent Receive Sensitivity
- Available with all Series 600 Ultrasonic sensors
- Specifically intended for operation in air at ultrasonic frequencies

Part No.

- *PID# 615088LF – Instrument Grade Smart Sensor
- *PID# 615089LF – Environmental Grade Smart Sensor
- *PID# 615090LF – Open Face Smart Sensor
- *PID# 615095LF – Environmental Grade Smart Sensor w/Parylene
- *RoHS Compliant

Benefits

- Self-Contained Compact Design
- Easy to Interface with Minimum of External Components
- Can be Triggered Internally or Externally
- Will Operate on a Power Source from 6 to 24 VDC

Applications

Level Measurement, Proximity Detection, Presence Detection, Robotics, Educational Products

Specifications

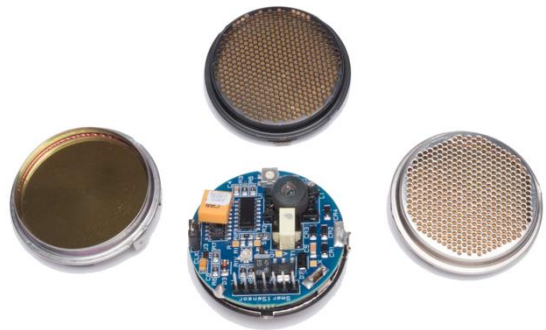

Description

The new SensComp Smart Sensor is based on the ultra-sensitive Series 600 Electrostatic Ultrasonic sensor line with an enhanced version of our 6500 ranging module on board. The new voltage regulated circuitry allows the sensor to operate from a 6 to 24 VDC power source.

The TTL compatible open collector outputs include pull-up resistors. Configuration of the new oscillator circuit enables the unit to be externally triggered or continually sense at 5 Hz.

The digitally controlled gain and variable bandwidth amplifier minimizes noise and side lobe detection in sonar applications. The typical absolute accuracy is $\pm 1\%$ of the reading over the entire range.

This new compact integrated design of SensComp's Series 600 Smart Sensor will expedite the product development process.

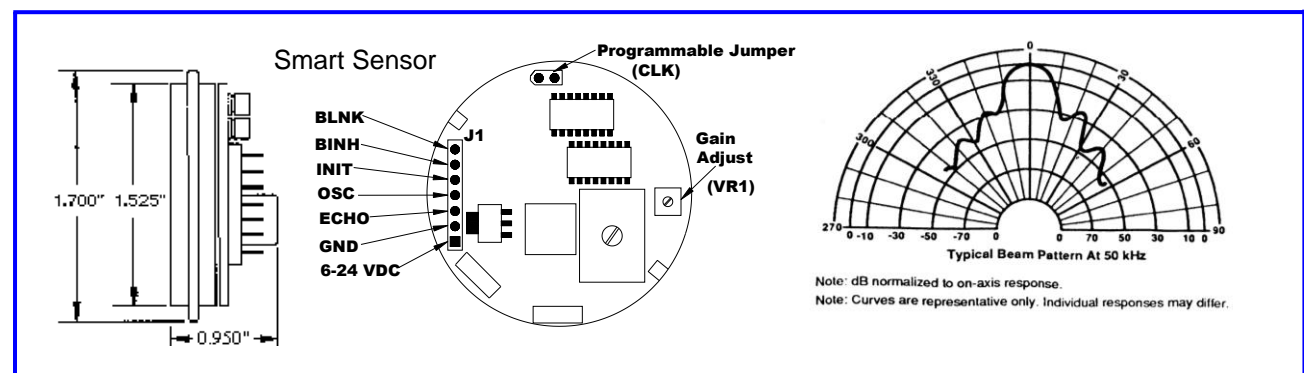

Series 600 Smart Sensor Specifications

Distance Range1.5 ft. to 35 ft. (0.5 ft. to 35 ft. capable)	Operating Temperature0° to +70° C (32° to 158° F)
Accuracy (over entire range) ± 0.1%	Dimensions:
Beam Pattern See Graph Typically 15° nominal.	Thickness0.950 inch
Repetition Rate (astable)..... 5 Hz May be externally triggered	Diameter1.700 inch
Outputs PWM (ECHO) Internal Pull-up resistors to +5 VDC	Mounting Diameter1.525 inch
Power Requirements	Housing, Standard Finish
Voltage 6 to 24 VDC	Instrument Grade Satin Black Painted 304 Stainless Steel
Current , during transmit 2 A	Environmental Grade 304 Stainless Steel
Current , after transmit (nominal) 55 mA	Open Face Parylene Coated 304 Stainless Steel
	Weight 19 grams (0.7 oz.)

System Wiring Information

- Pin 1 – Power Supply**-----Requires a +6 to +24 VDC regulated power source with a 100 mA current capacity, with short burst capability to 2 amperes during transmit.
- Pin 2 – Common**-----Return for DC power supply, TTL outputs and clock signals.
- Pin 3 – Echo Output**-----TTL compatible logic level output (0-5 VDC). Changes state when an echo signal is received.
- Pin 4 – OSC Output**-----TTL compatible logic level output (0-5 VDC). The internal 49.4 kHz oscillator output Note: this output is on only when the INIT signal (pin 5) is high.
- Pin 5 – INIT Input**-----TTL compatible logic level input or output (see “Programmable Jumper”): Initializes a Transmit/receive cycle on the low to high transition. This signal must remain high for the duration of the target detection period.
- Pin 6 – BINH Input**-----TTL compatible logic level input: Enables multiple target detection when high. Leave un-connected or connected to pin 2 for normal operation.
- Pin 7 – BLNK Input**-----TTL compatible logic level input. This input, when high, resets the receiver’s threshold so that multiple echoes’ can be detected after a single transmit. Leave un-connected or connected to pin 2 for normal operation.
- Programmable Jumper**---Internal 5 Hz repetition rate selected when jumper installed. Remove for external INIT input. When connected, an internal oscillator provides the INIT signal, and the INIT pin is an output.

Absolute Maximum Ratings over Operating Free-air temperature range

Voltage from any input/output pin to ground	7 VDC
Supply Voltage Input.....	26 VDC

Recommended Operating Conditions

	MIN	MAX	UNIT
Supply Voltage, Vcc	6.0	24.0	V
High-level Input Voltage, VIH	2.1		V
Low-level Input Voltage, VIL		0.6	V
INIT, ECHO and OSC Output Voltage		6.8	V
Delay Time, Power Up to INIT High	5		ms
Recycle Period	80		ms
Operating Free-air Temperature, T _A	0	70	°C

** INIT is a TTL compatible input for External Triggering; INIT is a TTL compatible output for Internal Triggering

Electrical Characteristics over Recommended Ranges of Supply Voltage and Operating Free-Air Temperature

PARAMETER		TEST COND.	MIN	TYP	MAX	UNIT
Input Current	BLNK, BINH, INIT**	$V_i = 2.1\text{ V}$			1	mA
High-level Output Current, I_{OH}	ECHO, OSC, INIT**	$V_{OH} = 5.5\text{ V}$			100	μA
Low-level Output Voltage, V_{OL}	ECHO, OSC, INIT**	$I_{OL} = 1.6\text{ mA}$			0.4	V
Internal Blanking Interval				2.38		ms
XMIT Drive Signal Duration				1.1		ms
Frequency During 16-pulse	OSC output			49.4		kHz
Transmit Period	XMIT output			49.4		kHz
Frequency After 16-pulse	OSC output			93.3		kHz
Transmit Period	XMIT output			0		kHz
Supply Current,	During transmit period				2000	mA
	After transmit period				100	mA

** INIT is a TTL compatible input for External Triggering; INIT is a TTL compatible output for Internal Triggering

Operation

The Series 600 Smart Sensor has two basic modes of operation: Single-echo mode and multiple-echo mode. The application of power (V_{CC}), the application of the initiate (INIT) input, the resulting transmit output, and the use of the Blanking Inhibit (BINH) input are basically the same for either mode of operation. After applying power, a minimum of 5 milliseconds must elapse before the INIT signal can be taken high. During this time, all internal circuitry is reset and the internal oscillator stabilizes. When INIT is raised to a high level, a transmit drive to the ultrasonic sensor (XDCR) occurs. Sixteen pulses at 49.4 kHz are transmitted from the ultrasonic sensor. At the end of the 16 transmitted pulses, a 200 VDC bias remains on the ultrasonic sensor (as recommended) for optimum receiving operation.

In order to eliminate the inherent ringing of the ultrasonic sensor after transmitting from being detected as a returning echo, the Receive (REC) input of the ranging control IC is inhibited by internal blanking for 2.38 milliseconds after the initiate (INIT) signal. If a reduced blanking time is desired, then the input BINH can be taken high to end the blanking of the Receive input any time prior to internal blanking. This may be desirable to detect objects closer than 1.33 feet (corresponding to 2.38 milliseconds) and may be done if ultrasonic sensor damping is sufficient so that ringing is not detected as a return signal.

Single Echo Mode

In the single-echo mode of operation (Figure 1), all that must be done next is to wait for the return of the transmitted signal, traveling at approximately 0.9 milliseconds per foot out and back. The returning signal is amplified and appears as a high logic level echo output. The time between INIT going high and the Echo (ECHO) output going high is proportional to the distance of the target from the ultrasonic sensor. If desired, the cycle can now be repeated by returning INIT to a low logic level and then taking it high when the next transmission is desired.

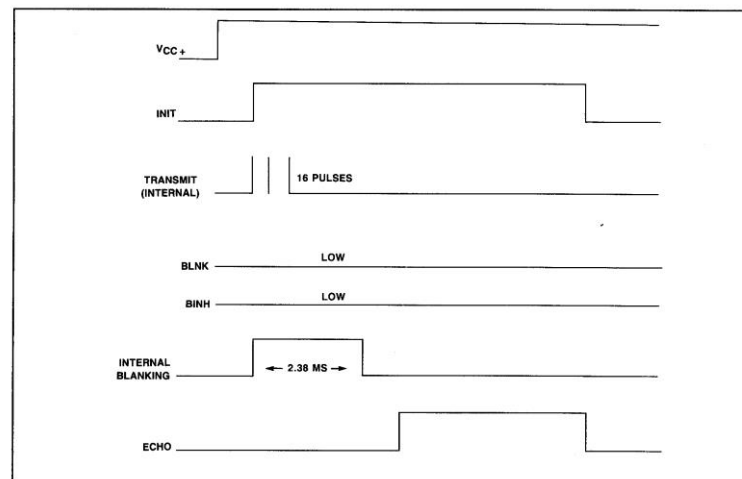

FIGURE 1: EXAMPLE OF A SINGLE-ECHO-MODE CYCLE WITHOUT BLANKING INPUT

Multiple Echo Mode

The Series 600 Smart Sensor has an external blanking input, BLNK, enabling selective echo exclusion for operation in a multiple echo mode and can differentiate echoes from objects that are only three inches apart. If there is more than one target and a single transmission detects multiple echoes, then the cycle is slightly different (Figure 2). After receiving the first return signal which causes the ECHO output to go high, the Blanking (BLNK) input must be taken high then back low to reset the ECHO output for the next return signal. The blanking signal must be at least 0.44 milliseconds in duration to account for all 16 returning pulses from the first target and allow for internal delay times. This corresponds to the two targets being 3 inches apart.

Gain Control and Gain Adjustment

During a cycle starting with INIT going high, the receiver amplifier gain is increased at discrete times (Figure 3) since the transmitted signal is attenuated with distance. At approximately 38 milliseconds, the maximum gain is attained. To calibrate the GAIN potentiometer, place the target at the maximum desired detection distance. Rotate the GAIN ADJUST potentiometer VR1 fully counter-clockwise (CCW). Then slowly rotate the GAIN control clockwise (CW) until detection occurs. Rotate the Gain control CW an additional 1/16 turn.

Note: Always calibrate the GAIN control for minimum gain required for reliable detection. Excessive gain may result in false target detection.

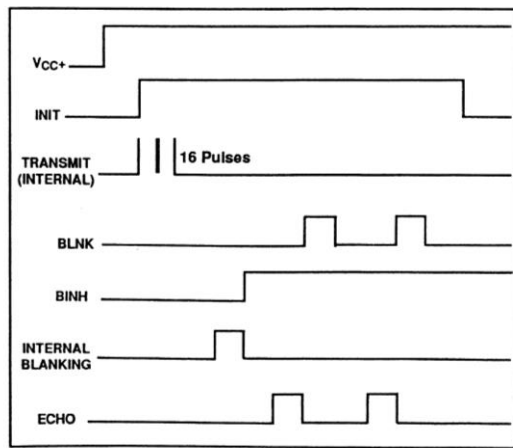

FIGURE 2: EXAMPLE OF A MULTIPLE-ECHO-MODE CYCLE WITH BLANKING INPUT

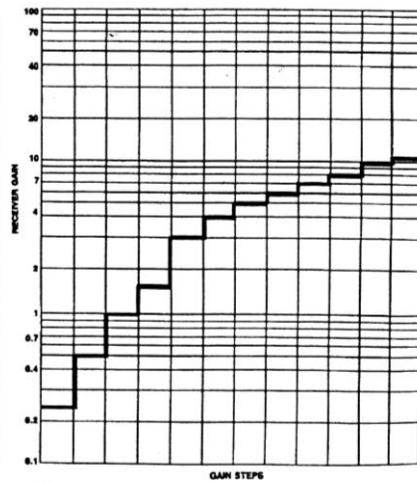
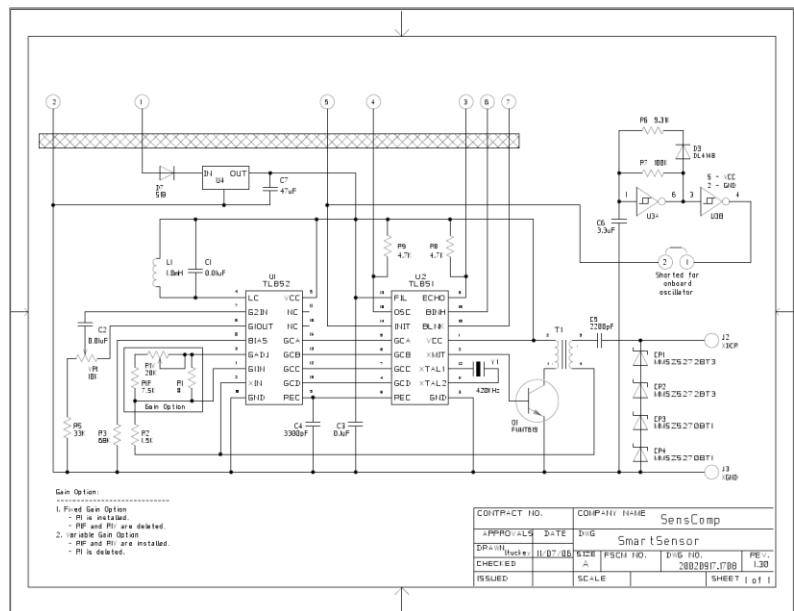
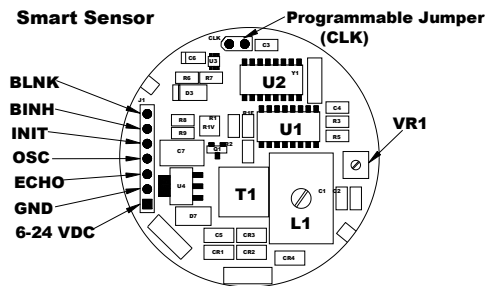

FIGURE 3: RECEIVER GAIN VS GAINSTEP NUMBERS

Schematic and Component Layout



Gain Option:
 1. Fixed Gain Option
 - PI is deleted.
 - RP and PIR are deleted.
 2. Variable Gain Option
 - RP and PIR are installed.
 - PI is deleted.

CONTRACT NO.	COMPANY NAME	SensComp
APPROVALS DATE	DATE	
DESIGN	PROJECT NO.	SmartSensor
CHECKED	DATE	20150317
ISSUED	SCALE	1:100
		SHEET 1 of 1

SENSCOMP PRODUCT SPECIFICATION SHEET DISCLAIMER NOTICE

SensComp, Inc. ("SensComp") reserves the right to make corrections, enhancements, improvements and other changes to its products, specification sheets and data, and to discontinue any product, without further notice. Buyer should obtain the latest relevant information before placing an order and should verify that such information is current and complete. All products are sold subject to SensComp's terms and conditions of sale in effect at the time of order acknowledgment.

SensComp disclaims any and all liability for any errors, inaccuracies or incompleteness contained in any specification sheet or in any other disclosure relating to any product. Information contained herein is strictly for reference and subject to change without notice. SensComp is not liable for any damages that the reader or any third person might suffer as a result of the reader ignoring this warning.

SensComp makes no warranty, representation or guarantee regarding the suitability of the products for any particular purpose. SensComp disclaims (i) any and all liability arising out of the application or use of any product, (ii) any and all liability, including without limitation special, consequential or incidental damages, and (iii) any and all implied warranties, including warranties of fitness for a particular purpose, non-infringement and merchantability.

SensComp assumes no liability for applications assistance or the design of Buyer's products. Buyer is responsible to validate its products, designs and applications using SensComp's products or components. To minimize the risks associated with Buyer's products and applications, Buyer should provide adequate design and operation safeguards.

SensComp products are not authorized for use in aircraft, aviation, nuclear, medical or safety-critical applications including, but not limited to, life support, where a failure of the SensComp product would reasonably be expected to cause severe personal injury or death.