

SonaSwitch® 1650S

The SonaSwitch® 1650S electrostatic ultrasonic transducer system, with laser aiming, provides a complete sensor solution to simplify your product design and packaging.

Features

- 50 KHz Electrostatic Ultrasonic Transducer with Integrated SMT Electronic Circuitry
- TWO (2) Independent Push-button Programmable Detection Ranges
- Form C (NO/NC) Relay Output for each Range
- Range Detection and Power LED Indicators
- Range of Detection is 6" – 20'
- Temperature Compensated Switch-point Output

Part No.

*PID# 800040LF – SonaSwitch® 1650S (6' Cable Included)
*RoHS Compliant

Benefits

- Self-Contained Compact Design
- Can be Triggered Internally or Externally
- Range Detection from 6" to 20'
- Excellent Receive Sensitivity
- Simple Push Button Range Programming for Quick and Easy Set-up

Applications

Level Measurements, Proximity Detection, Presence Detection, Robotics, Educational Products

Specifications



Description

The SonaSwitch® 1650S ultrasonic sensor provides a total system in a complete package containing an ultra-sensitive electrostatic transducer and supporting circuitry to provide two independent relay contact outputs, each independently push-button programmable, indicating the detection of a target between 6 inches and 20 feet away. The SonaSwitch® 1650S can be externally triggered, or continually sense at a 10 HZ rate. The SonaSwitch® 1650S is insensitive to temperature, humidity and pressure changes. The sensor can also withstand high audio and EMI/RFI levels.

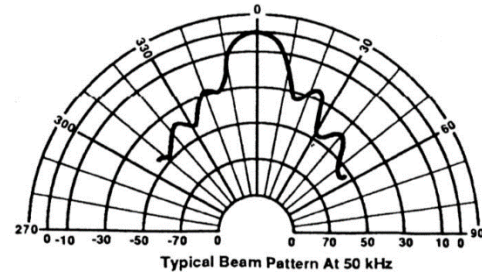
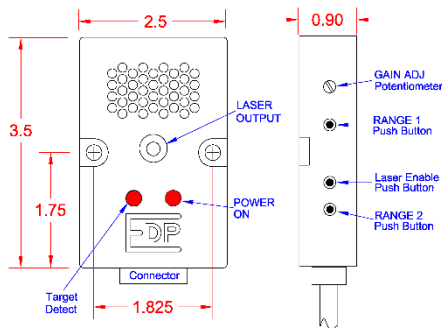

Note: dB normalized to on-axis response.
Note: Curves are representative only. Individual responses may differ.

SonaSwitch® 1650S Specifications

Distance Ranges:0.15 – 6.10 M (0.5 - 20 feet)

Switch Point Accuracy: (over entire range).....± 0.1%

Beam Pattern:..... See Graph
Typically 15° nominal.

Repetition Rate: (astable)..... 10 Hz
May be externally triggered up to a 50 Hz rate

Outputs: Form C Relay Outputs.....2

- Relay continuously energized during the detection period.
- Relay Contacts rated at:
 - 0.4 amps, 125 VAC resistive
 - 1.25 amps, 24VDC resistive

Relay Response Time:

0.5 seconds nominal from start of detection to relay closure; 0.5 second nominal shut-off time

Specifications subject to change without notice

Power Requirements: 12 to 24 VAC; 10 to 30 VDC
(Maximum current = 0.15 A; 0.08 A average)

Operating Temperature:.....-40 to +85° C
(-40 to 185° F)

Weight: (approximately)..... 198 grams (7.0 oz)

Dimensions:

Height 8.89cm (3.50 inch)

Width..... 5.72 cm ... (2.25 inch)

Depth 2.29 cm ... (0.90 inch)

Mounting: Two (2) No.10 (5/32") machine screws
mounted flat on 1.85" centers.

Cable:..... Supplied with a 6 foot cable

Case Material: High temperature electroplated
ABS Plastic

Case Color:..... Medium Blue

General Installation Procedures

1. Always mount the SonaSwitch® 1650S in a suitable dry location. The SonaSwitch® 1650S is designed for use in indoor or protected environments only. Excessive moisture in the circuit board and transducer will result in damage and improper operation, and will void all warranties.
2. Mount the SonaSwitch® 1650S as far off the ground as practical (minimum of 24 inches).
3. Adjust the gain to the minimum setting necessary to ensure reliable target detection. (Excessive gain can result in false detections).
4. Mount the SonaSwitch® 1650S in a location where environmental interference sources are minimized (examples: EMI sources, air nozzles, excessive air turbulence, rain or snow, etc.).

Calibration

Calibrating the SonaSwitch® 1650S is as simple as placing a target in front of the sensor and setting the range by depressing the appropriate push button. The SonaSwitch® 1650S also incorporates a laser which allows precise positioning of the sensor with relationship to the target.

For detailed installation and calibration procedures, refer to the Installation instructions included with your SonaSwitch® 1650S.

WARNING

**NEVER LOOK DIRECTLY INTO THE LASER LIGHT WHEN ACTIVATED
DOING SO MAY CAUSE PERMANENT DAMAGE TO YOUR EYES AN/OR VISION**

Cable Wiring Information

Conn. Pin #	Wire Color	Function	Description
1	RED	POWER INPUT	12-24 VAC/20-30VDC Power Input
2	BLACK	POWER INPUT	12-24 VAC/20-30VDC Power Input
3	WHITE	N.O. 1	Relay 1 - Normally Open Contact
4	YELLOW	COM 1	Relay 1 - Common
5	ORANGE	N.C. 1	Relay 1 - Normally Closed Contact
6	BLUE	EXT. TRIG.	External Trigger Input
7	BROWN	ECHO OUT	TTL Level PWM Clock Output
8	GREEN	GND	Ground Return (Common)
9	VIOLET	N.O. 2	Relay 2 - Normally Open Contact
10	GRAY	COM 2	Relay 2 - Common
11	PINK	N.C. 2	Relay 2 - Normally Closed Contact
12	BROWN/WHITE		
13	BLACK/WHITE	EXTERNAL TRIGGER ENABLE	Enable External Trigger Input (pin #6)
14	RED/WHITE	RECV. OUT	Internal Receiver Test Output
15	LIGHT GREEN	LASER EN.	Enable Laser Pointer
SHELL	DRAIN		

SENSCOMP PRODUCT SPECIFICATION SHEET DISCLAIMER NOTICE

Information provided in this document is proprietary to SensComp, Inc. ("SensComp") and SensComp reserves the right to make corrections, enhancements, improvements and other changes to its products, specification sheets and data, and to discontinue any product at any time, without further notice. Buyer should obtain the latest relevant information before placing an order and should verify that such information is current and complete. All products are sold subject to SensComp's terms and conditions of sale in effect at the time of order acknowledgment.

SensComp disclaims any and all liability for any errors, inaccuracies or incompleteness contained in any specification sheet or in any other disclosure relating to any product. Information contained herein is strictly for reference and subject to change without notice. SensComp is not liable for any damages that the reader or any third person might suffer as a result of the reader ignoring this warning.

SensComp makes no warranty, representation or guarantee regarding the suitability of the products for any particular purpose. SensComp disclaims (i) any and all liability arising out of the application or use of any product, (ii) any and all liability, including without limitation special, consequential, or incidental damages, and (iii) any and all implied warranties, including warranties of fitness for a particular purpose, non-infringement, and merchantability.

Any performance specs are believed to be reliable but are not verified, and buyer must conduct and complete all performances and other testing of the products, alone and together, with, or installed in any end-product. Buyer shall not rely on any data and performance specs or parameters provided by SensComp.

SensComp assumes no liability for applications assistance or the design of Buyer's products. Buyer is responsible to independently determine suitability of any products and to test, verify and validate its products, designs and applications using SensComp's products or components. To minimize the risks associated with Buyer's products and applications, Buyer should provide adequate design and operation safeguards.

The information provided by SensComp here under is provided "as is, where is" and with all faults, and the entire risk associated with such information is entirely with buyer. SensComp does not grant, explicitly or implicitly, to any party any patent rights, licenses, or any other IP rights, whether with regard to such information itself or anything described by such information.

SensComp products have been subject to limited testing and are not authorized for use in aircraft, aviation, nuclear, medical, or safety-critical applications including, but not limited to, life support, and where a failure of the SensComp product would reasonably be expected to cause severe personal injury or death.