

VERIFYING SONASWITCH® MINI-A/AE SENSOR OPERATION

Connecting the SonaSwitch® Mini-A to Power and External Electronics

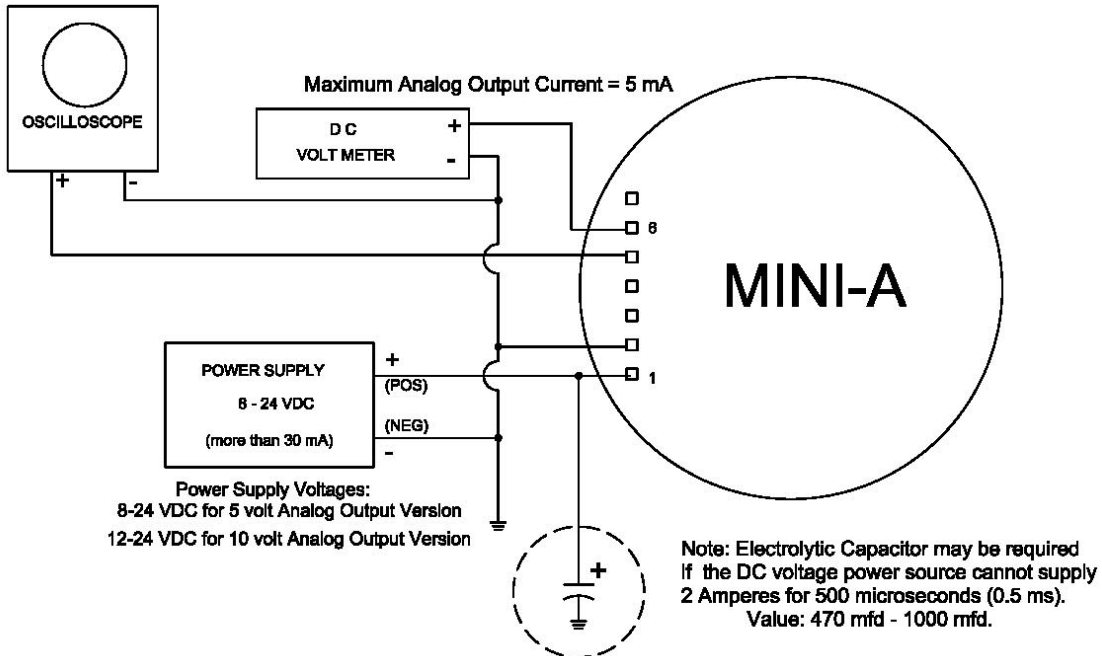

Checking SonaSwitch® Mini-A Operation:

1. Connect Power Supply to SONASWITCH® MINI-A (+ to pin 1, - to pin 2). Using a DC voltmeter, verify the voltage is correct AT the SonaSwitch® Mini-A, pins 1 and 2.
2. If connected, disconnect EXT TRIG (pin 3) and TRIG ENABLE (pin 4). When not using external triggering, these pins can be left unconnected. If your system has excessive ground noise, you may have to tie these two pins to the + POWER SUPPLY (pin 1).
3. Re-Check ALL connections. Many suspected problems have been resolved because of wiring errors or poor connections.
4. Apply power to SonaSwitch® Mini-A. You should hear a “ticking” sound, occurring 5-10 times a second. If not, re-check the power voltage input. The ticking sound is created every time the Sensor transmits an ultrasonic pulse out.
5. After verifying the “ticking”, cover the face of the transducer with a stiff piece of flat paper. Verify the analog voltage output is either 5VDC or 10VDC, depending on which SonaSwitch® Mini-A version you have purchased. By moving the paper away from the transducer, the analog voltage should change from a low voltage at close range to the maximum voltage at the far range of the sensor, as set by the “zero” and “full-scale” potentiometer settings.
6. If you cannot obtain an analog output, verify the digital operation of the sensor with an oscilloscope as follows:
- 7.

Connect the oscilloscope vertical channel 1 to CLOCK (Pin 5). Use this channel as the oscilloscope trigger. Set the trigger to trigger on the waveform's rising edge.

- Verify that the Pulse Width Modulated (PWM) output waveform varies with distance between the transducer and the target. The time that the waveform is Logic 1 (High) will be approximately 17.5 milliseconds for a 3-meter distance between the transducer and the target, and 62.3 milliseconds for a 10.7-meter distance:

Clock (pin 5) Waveforms

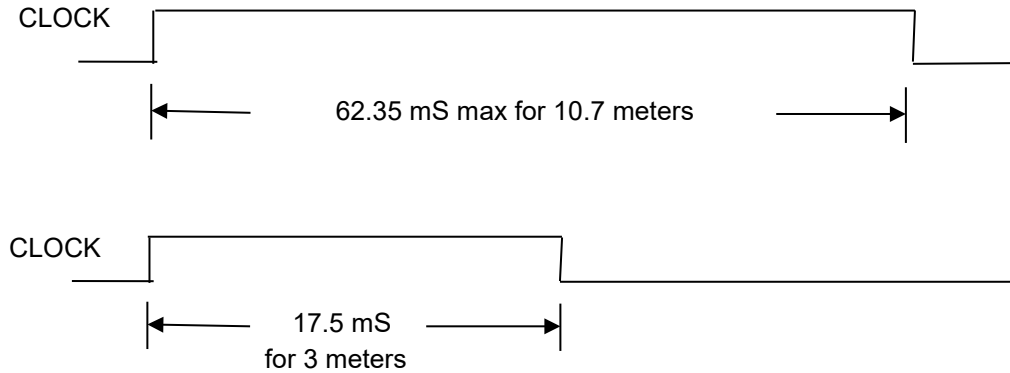

Wiring Information

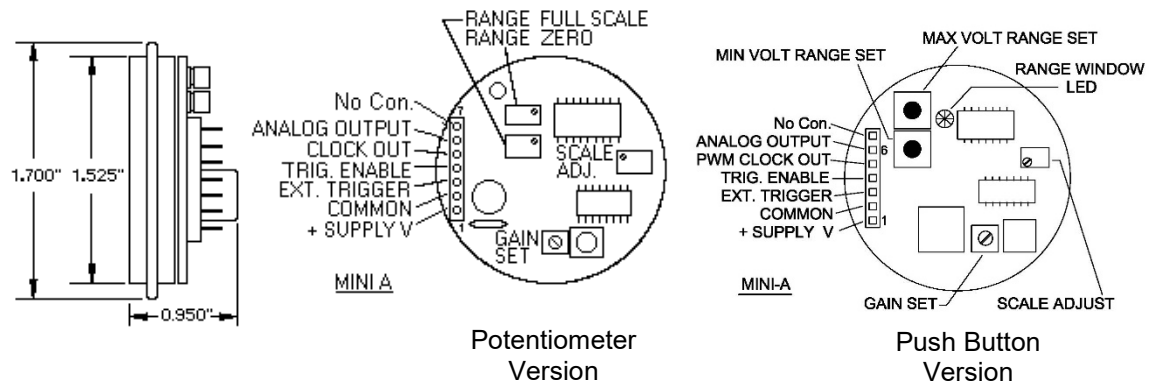

System Wiring Information

- Pin 1** – Power Supply -----Requires a +8 to +24 VDC regulated power source with a 30 mA current capacity (the 0 to 10 VDC analog output version requires a +12 to +24 VDC power source).
- Pin 2** – Common-----Common Return for DC power supply, analog output, and clock signals.
- Pin 3** – External Trigger -----Accepts TTL compatible logic level clock signals (0-5 VDC).
- Pin 4** – Trigger Enable-----Allows the SONASWITCH® MINI-A to accept an external trigger signal. Enable by connecting this pin (pin 4) to common (pin 2).
- Pin 5** – Clock Output -----Delivers a TTL compatible echo return clock signal (0-5 VDC). This signal goes high at the start of a cycle and returns to a low state when the returned echo from a target is detected.
- Pin 6** – Analog Output -----0 to +5 VDC (or 0 to +10 VDC) analog measurement output.